



Timing Chain

Special Tool(s) / General Equipment

	303-448 (T93P-6303-A) Holding Tool, Crankshaft TKIT-1993-FLM TKIT-1993-LM
---	--

Removal

NOTICE: The timing chain procedure has changed from prior model year engines and must be followed exactly or damage to the engine will result.

NOTICE: During engine repair procedures, cleanliness is extremely important. Any foreign material, including any material created while cleaning gasket surfaces, that enters the oil passages, coolant passages or the oil pan, can cause engine failure.

NOTE: In order to remove the LH timing chain, the RH timing chain must be removed first.

RH and LH timing chains

1. Remove the engine front cover.
Refer to: [Engine Front Cover](#) (303-01C Engine - 5.0L 32V Ti-VCT/5.0L Ti-VCT V8 (308kW/418PS), Removal and Installation).
2. Using the special tool, rotate the crankshaft clockwise until the keyway is at the 12 o'clock position.
Use Special Service Tool: [303-448 \(T93P-6303-A\) Holding Tool, Crankshaft](#).

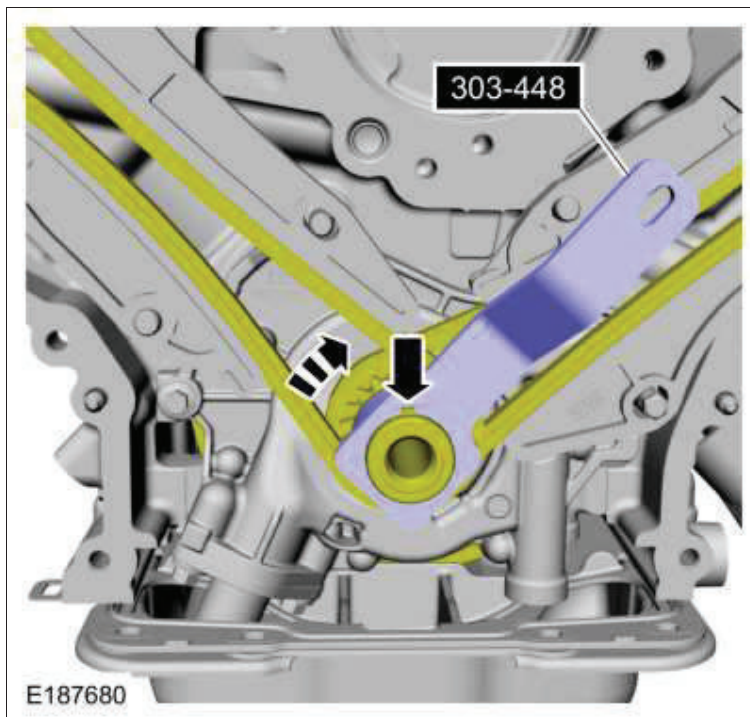

3. Verify the timing mark on the RH VCT unit is on top, if not, rotate the crankshaft clockwise one complete revolution so the keyway is at the 12 o'clock position.

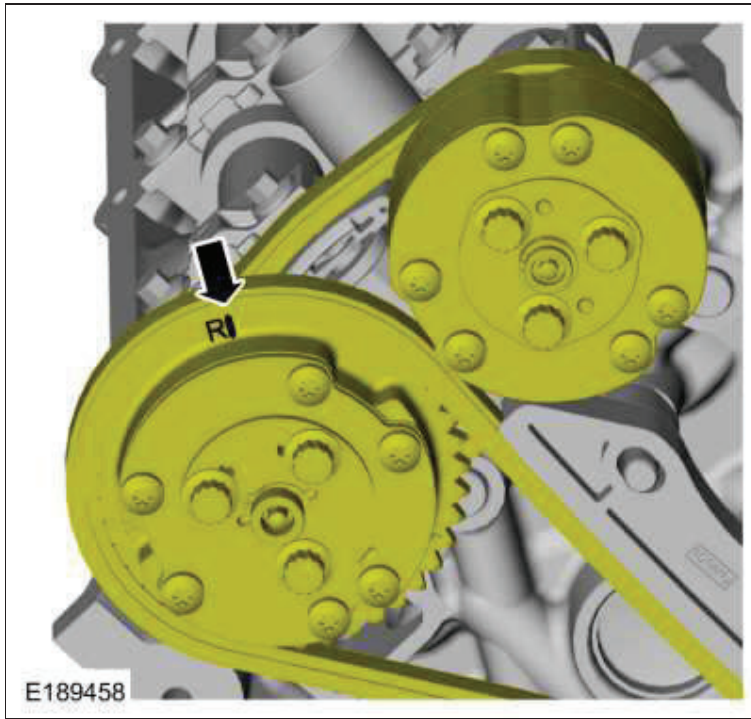

4. Remove the bolts and the RH primary timing chain tensioner.

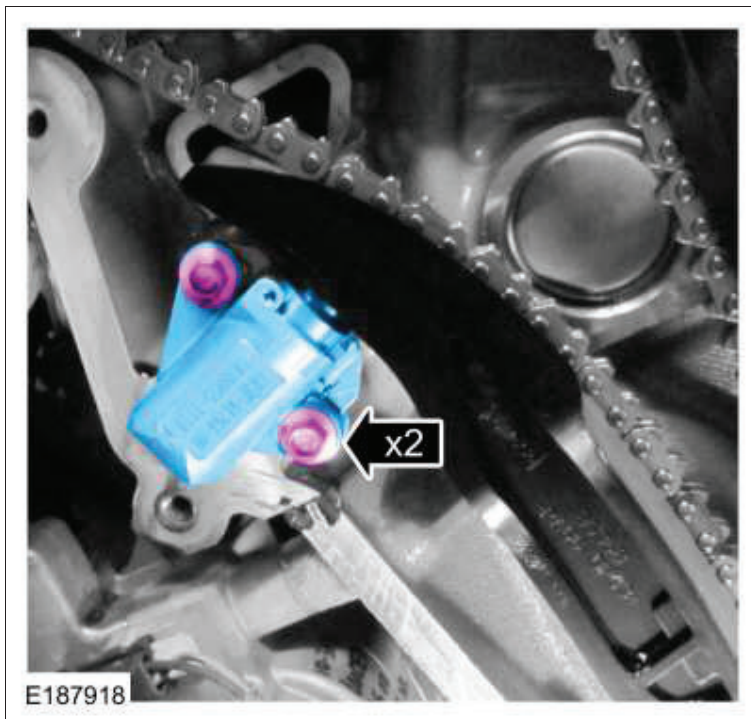

5. **NOTE:** It may be necessary to rotate the crankshaft slightly to provide enough slack in the chain to remove the RH timing chain tensioner arm. Return the crankshaft keyway to the 12 o'clock position after removing the RH timing chain tensioner arm.

Remove the RH timing chain tensioner arm.

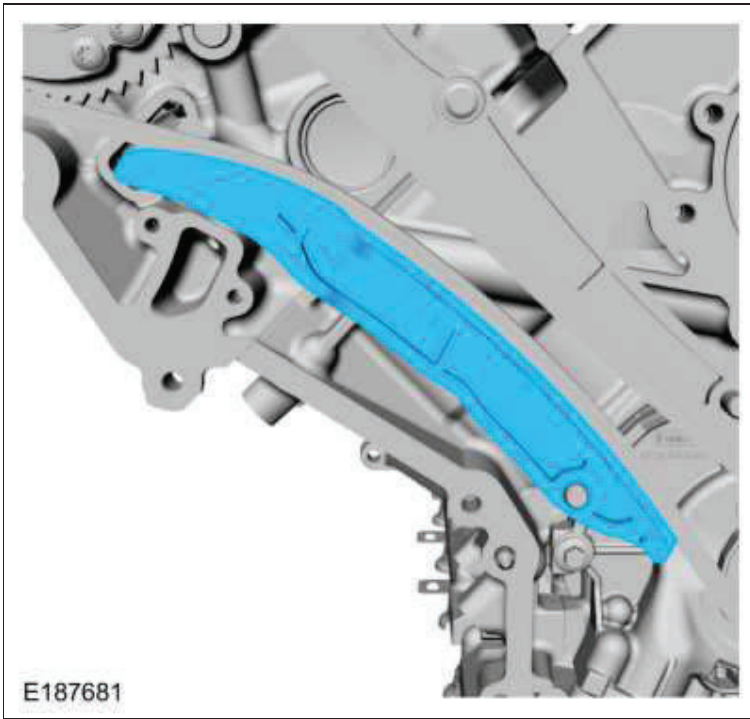

6. **NOTE:** It may be necessary to rotate the crankshaft slightly to provide enough slack in the chain to remove the RH timing chain guide. Return the crankshaft keyway to the 12 o'clock position after removing the RH timing chain guide.

Remove the bolt and the RH timing chain guide.

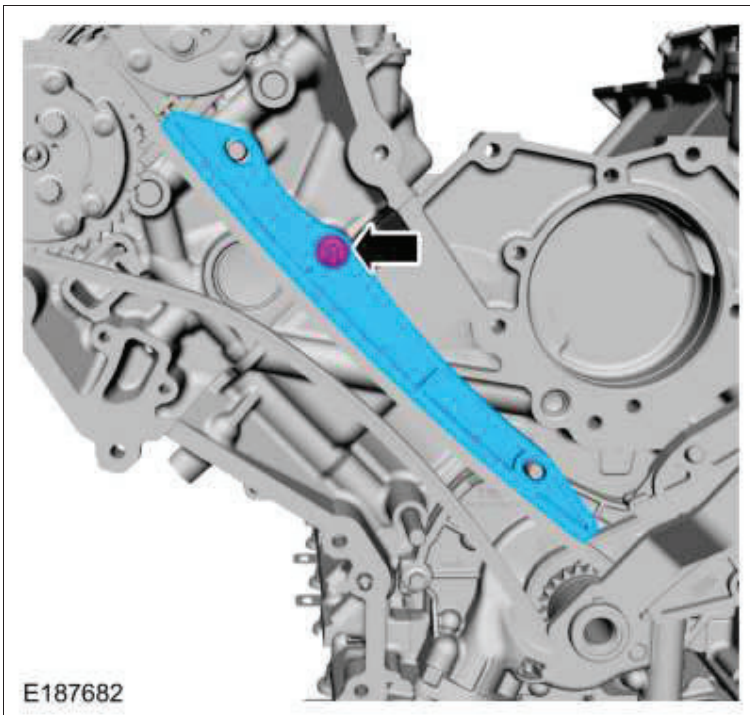

7. Remove the RH timing chain.

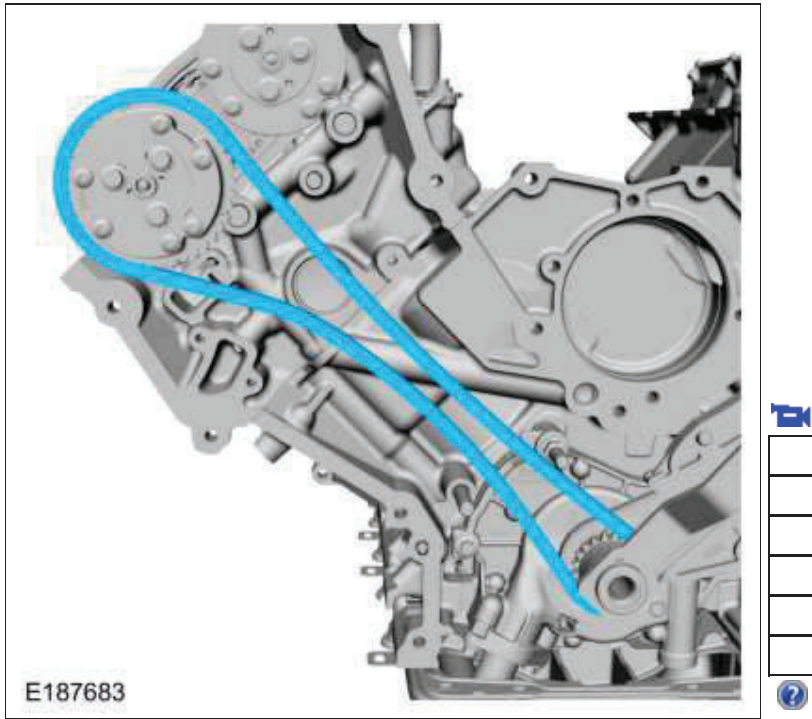

LH timing chain

- Using the special tool, rotate the crankshaft clockwise until the keyway is at the 5 o'clock position. Use Special Service Tool: [303-448 \(T93P-6303-A\) Holding Tool, Crankshaft](#).

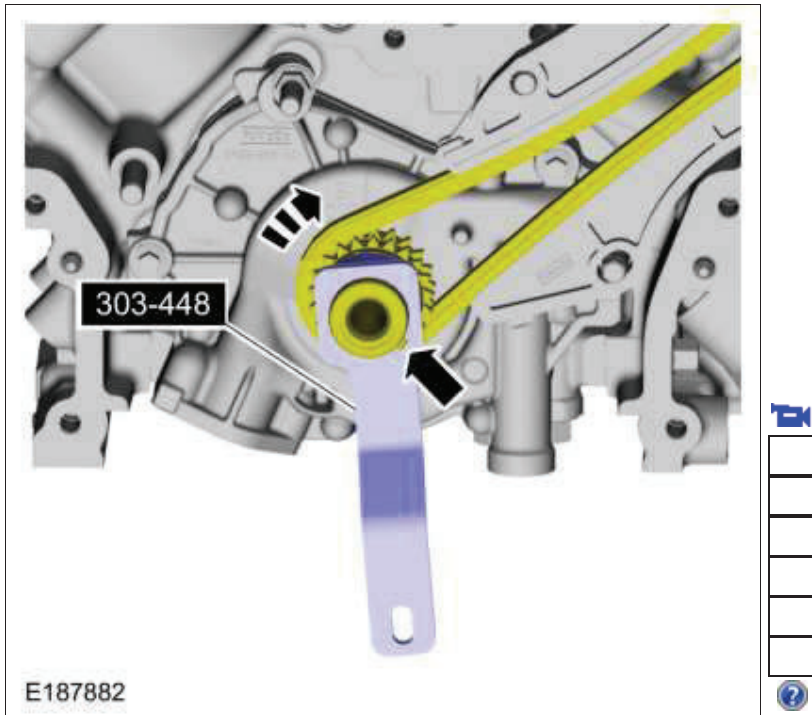

- Remove the bolts and the LH primary timing chain tensioner.

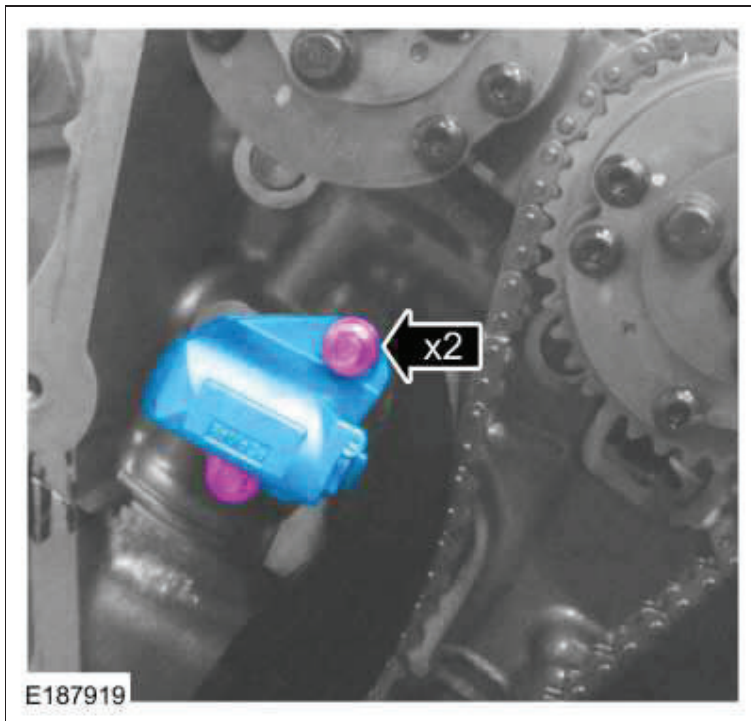

10. **NOTE:** It may be necessary to rotate the crankshaft slightly to provide enough slack in the chain to remove the LH timing chain tensioner arm. Return the crankshaft keyway to the 5 o'clock position after removing the LH timing chain tensioner arm.

Remove the LH timing chain tensioner arm.

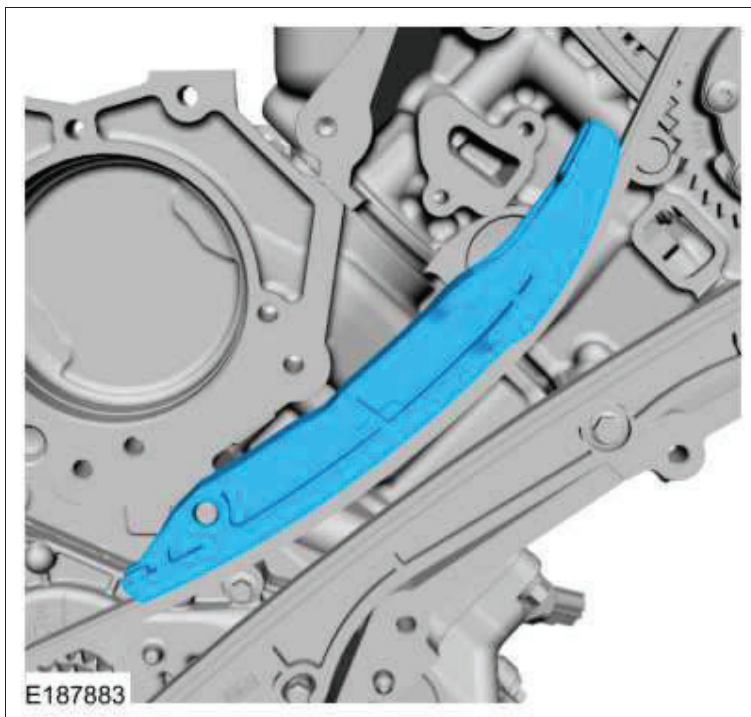

11. **NOTE:** It may be necessary to rotate the crankshaft slightly to provide enough slack in the chain to remove the LH timing chain guide. Return the crankshaft keyway to the 5 o'clock position after removing the LH timing chain guide.

Remove the bolt and the LH timing chain guide.

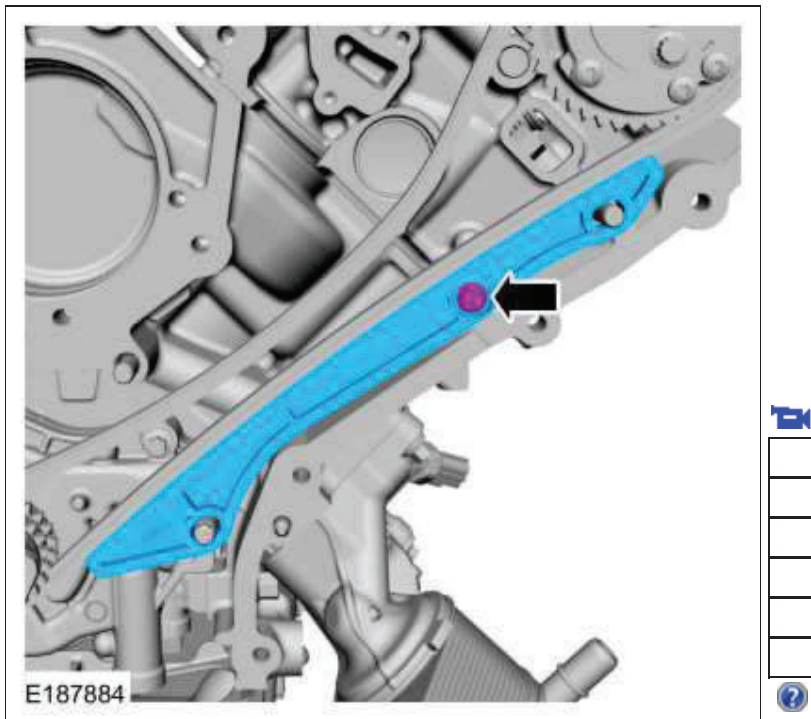

12. Remove the LH timing chain.

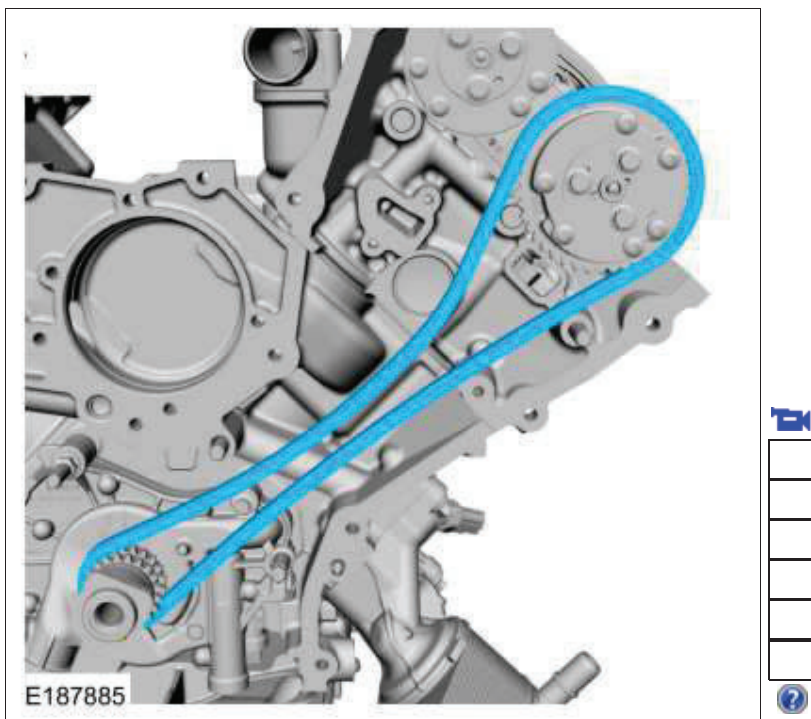

Installation

LH timing chain

1. Install the LH timing chain.
 - Align the colored link on the timing chain with the timing mark on the LH VCT assembly.
 - Align the remaining colored link on the timing chain with the timing mark on the crankshaft sprocket.

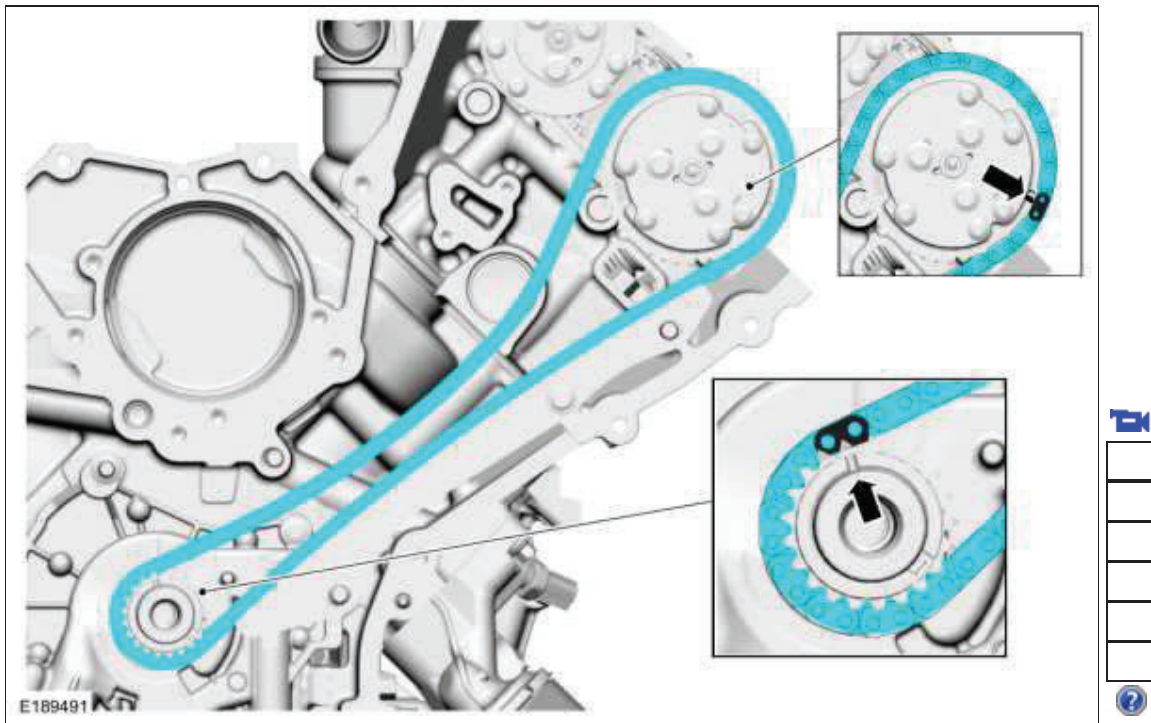

2. **NOTE:** It may be necessary to rotate the crankshaft slightly to provide enough slack in the chain to install the LH timing chain guide. Return the crankshaft keyway to the 5 o'clock position after installing the LH timing chain guide.

Install the LH timing chain guide and bolt.
 Torque: 89 lb.in (10 Nm)

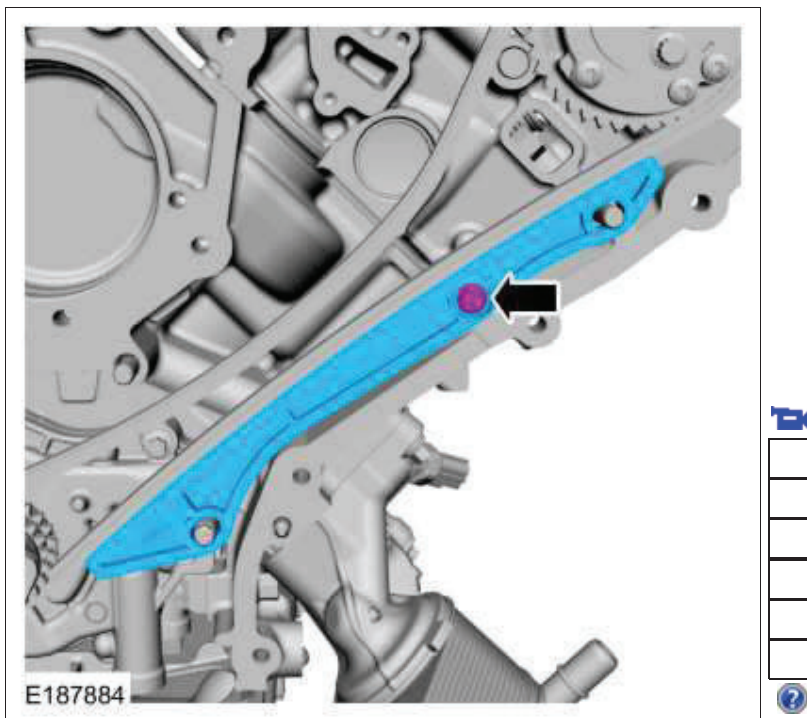

3. **NOTE:** It may be necessary to rotate the crankshaft slightly to provide enough slack in the chain to install the LH timing chain arm. Return the crankshaft keyway to the 5 o'clock position after installing the LH timing chain arm.

Install the LH timing chain tensioner arm.

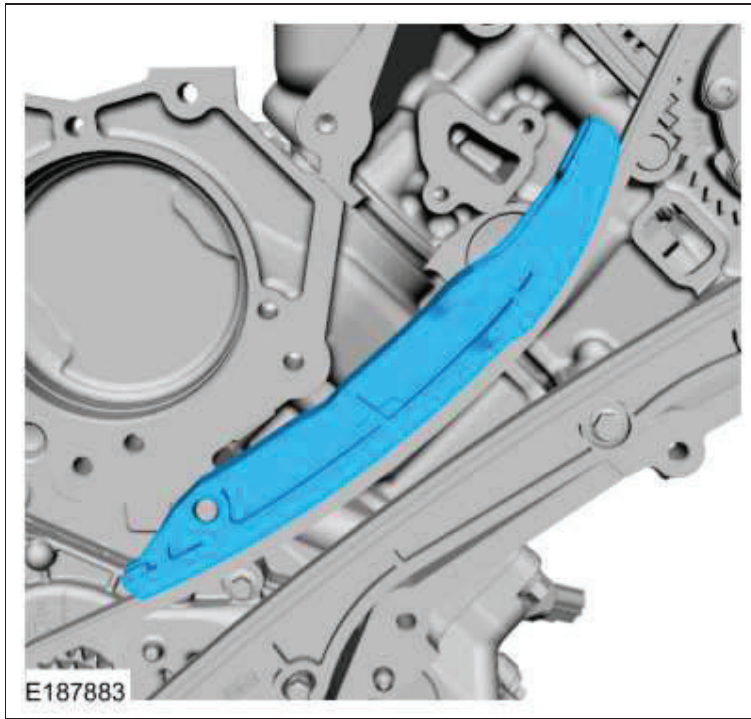

4.
 1. Compress the primary timing chain tensioner plunger, using an edge of a vise.
 2. Install a suitable pin into the hole of the tensioner housing to hold the plunger in place during installation.

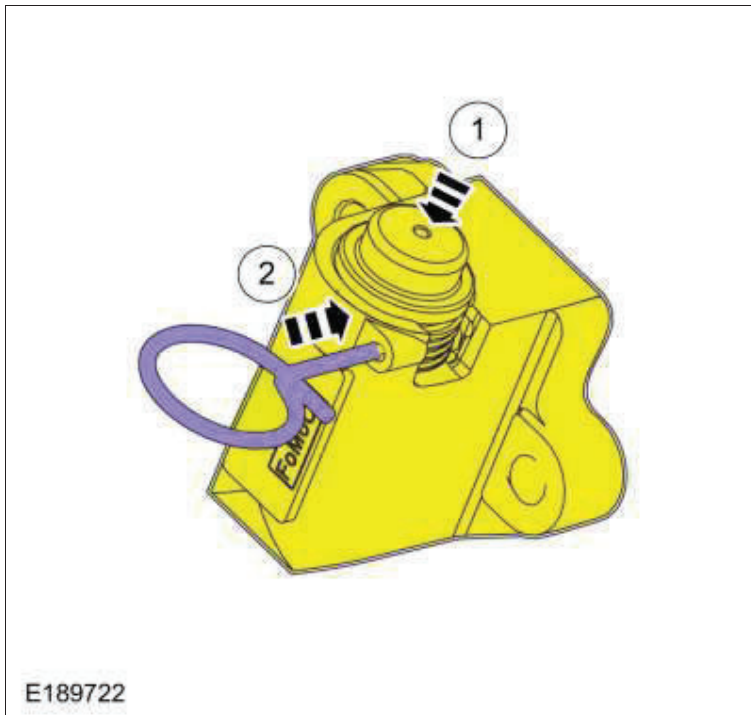

5.
 1. Install the LH primary timing chain tensioner and bolts.
Torque: 89 lb.in (10 Nm)
 2. Remove the holding pin from the tensioner.

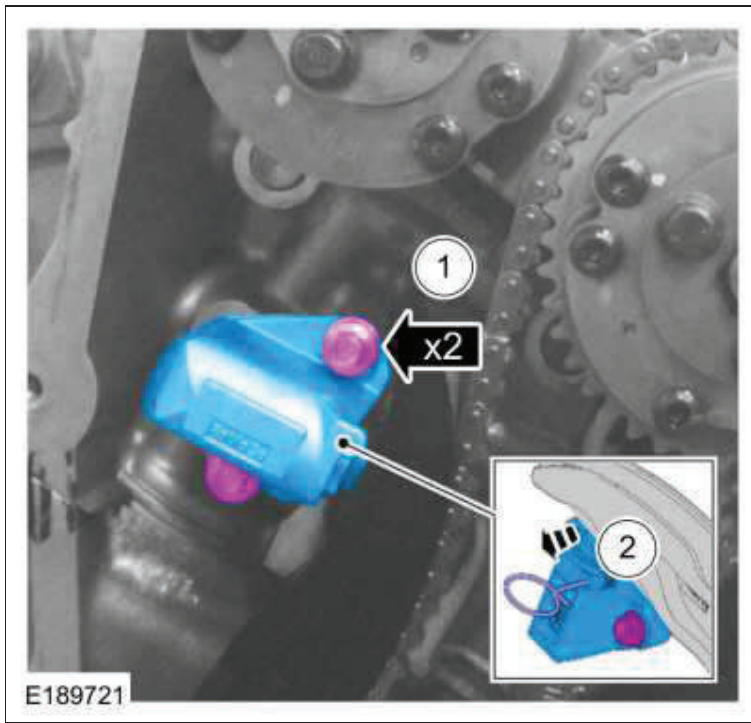

6. Using the special tool, rotate the crankshaft clockwise one complete revolution.
 Use Special Service Tool: [303-448 \(T93P-6303-A\) Holding Tool, Crankshaft](#).

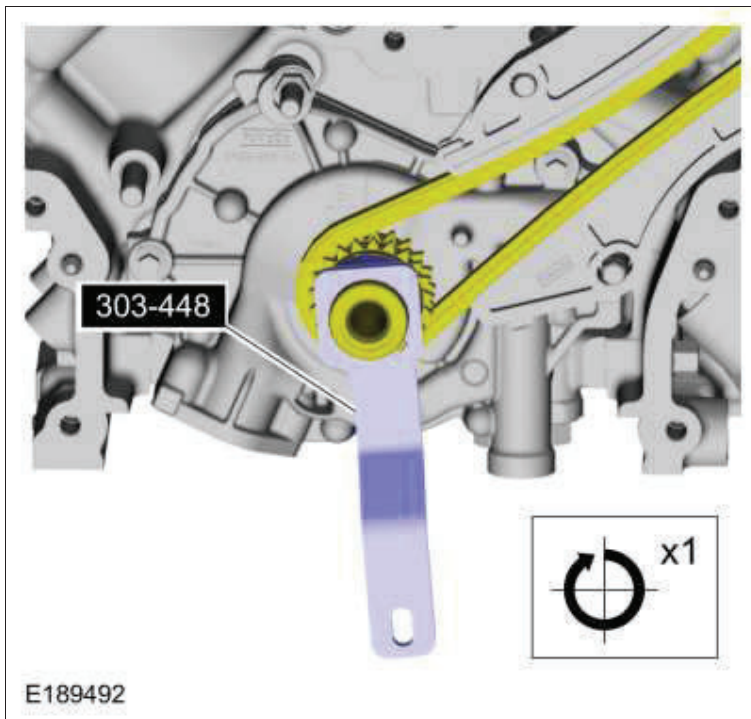

7. Using the special tool, rotate the crankshaft clockwise until the keyway is at the 12 o'clock position.
 Use Special Service Tool: [303-448 \(T93P-6303-A\) Holding Tool, Crankshaft](#).

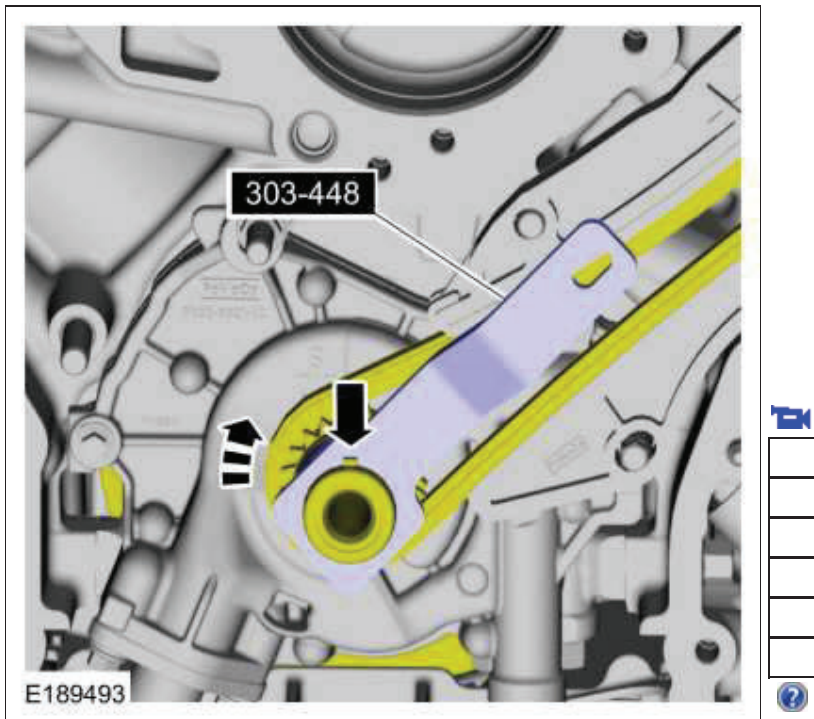

RH and LH timing chains

8. Install the RH timing chain.

- Align the colored link on the timing chain with the timing mark on the RH VCT assembly.
- Align the remaining colored link on the timing chain with the timing mark on the crankshaft sprocket.

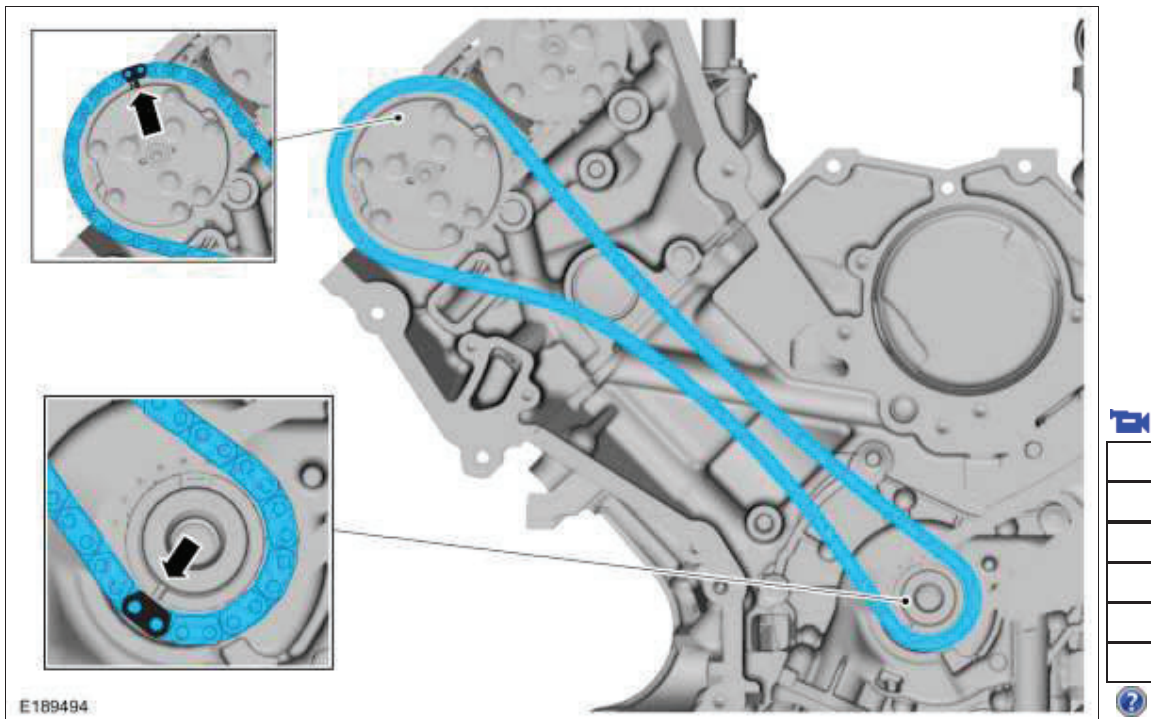

9. **NOTE:** It may be necessary to rotate the crankshaft slightly to provide enough slack in the chain to install the RH timing chain guide. Return the crankshaft keyway to the 12 o'clock position after installing the RH timing chain guide.

Install the RH timing chain guide and bolt.
Torque: 89 lb.in (10 Nm)

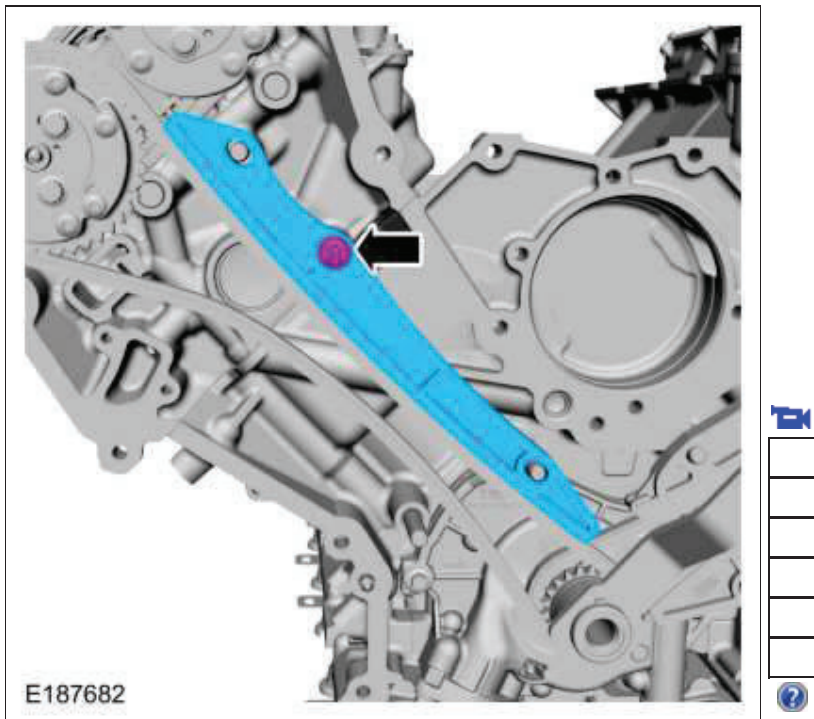

10. **NOTE:** It may be necessary to rotate the crankshaft slightly to provide enough slack in the chain to install the RH timing chain arm. Return the crankshaft keyway to the 12 o'clock position after installing the RH timing chain arm.

Install the RH timing chain tensioner arm.

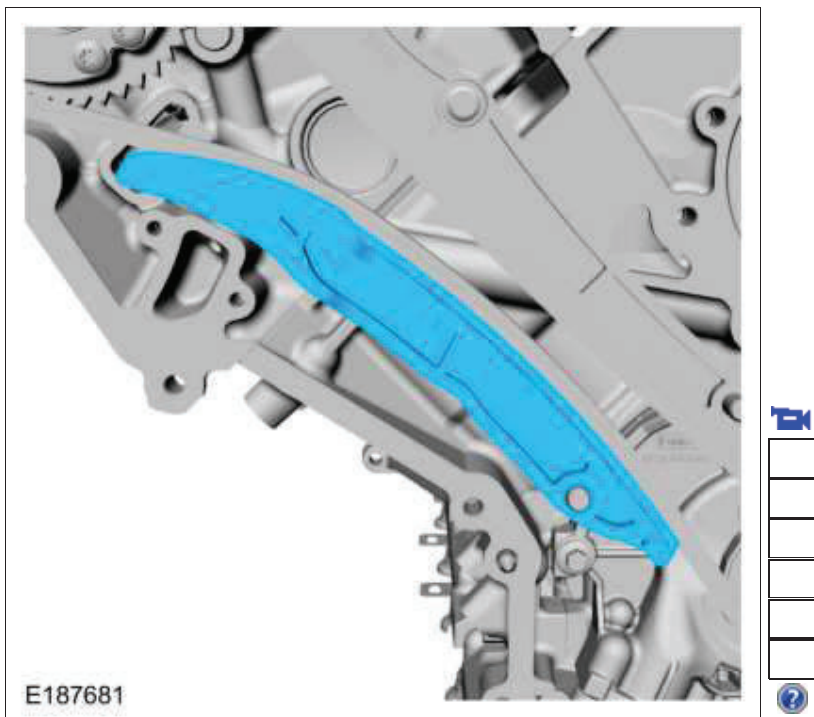

11.
 1. Compress the primary timing chain tensioner plunger, using an edge of a vise.
 2. Install a suitable pin into the hole of the tensioner housing to hold the plunger in place during installation.

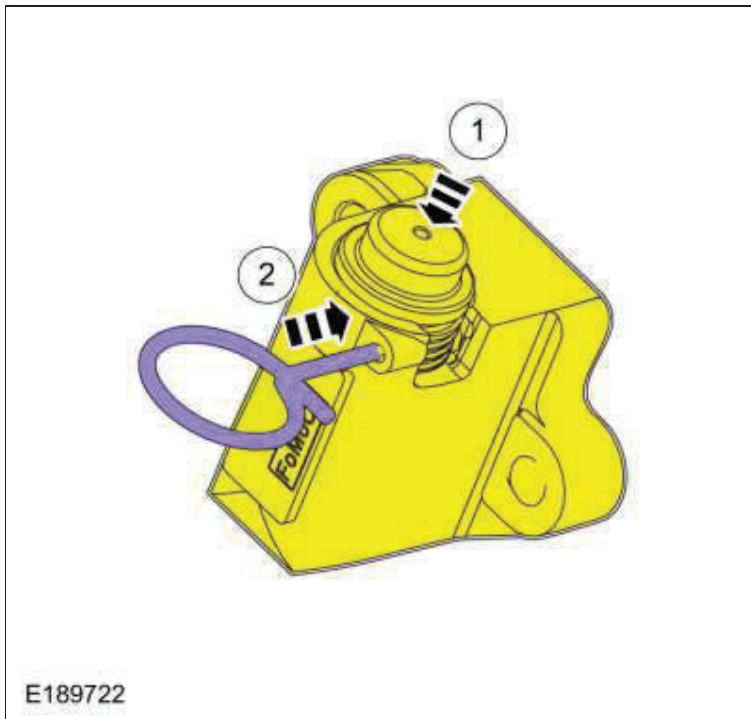

12.
 1. Install the **RH** primary timing chain tensioner and bolts.
Torque: 89 lb.in (10 Nm)
 2. Remove the holding pin from the tensioner.

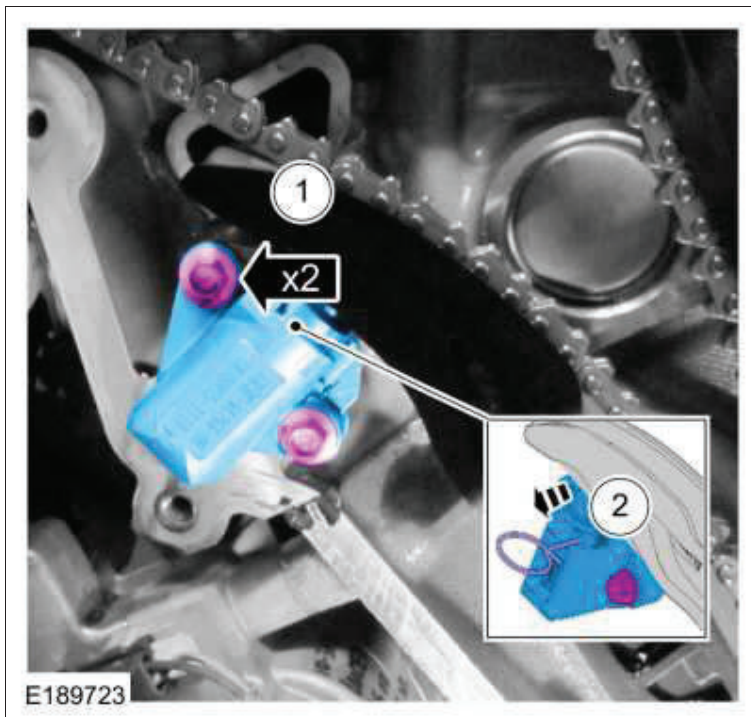

13. Install the engine front cover.
Refer to: [Engine Front Cover](#) (303-01C Engine - 5.0L 32V Ti-VCT/5.0L Ti-VCT V8 (308kW/418PS), Removal and Installation).