

Electronic Engine Controls - Component Location

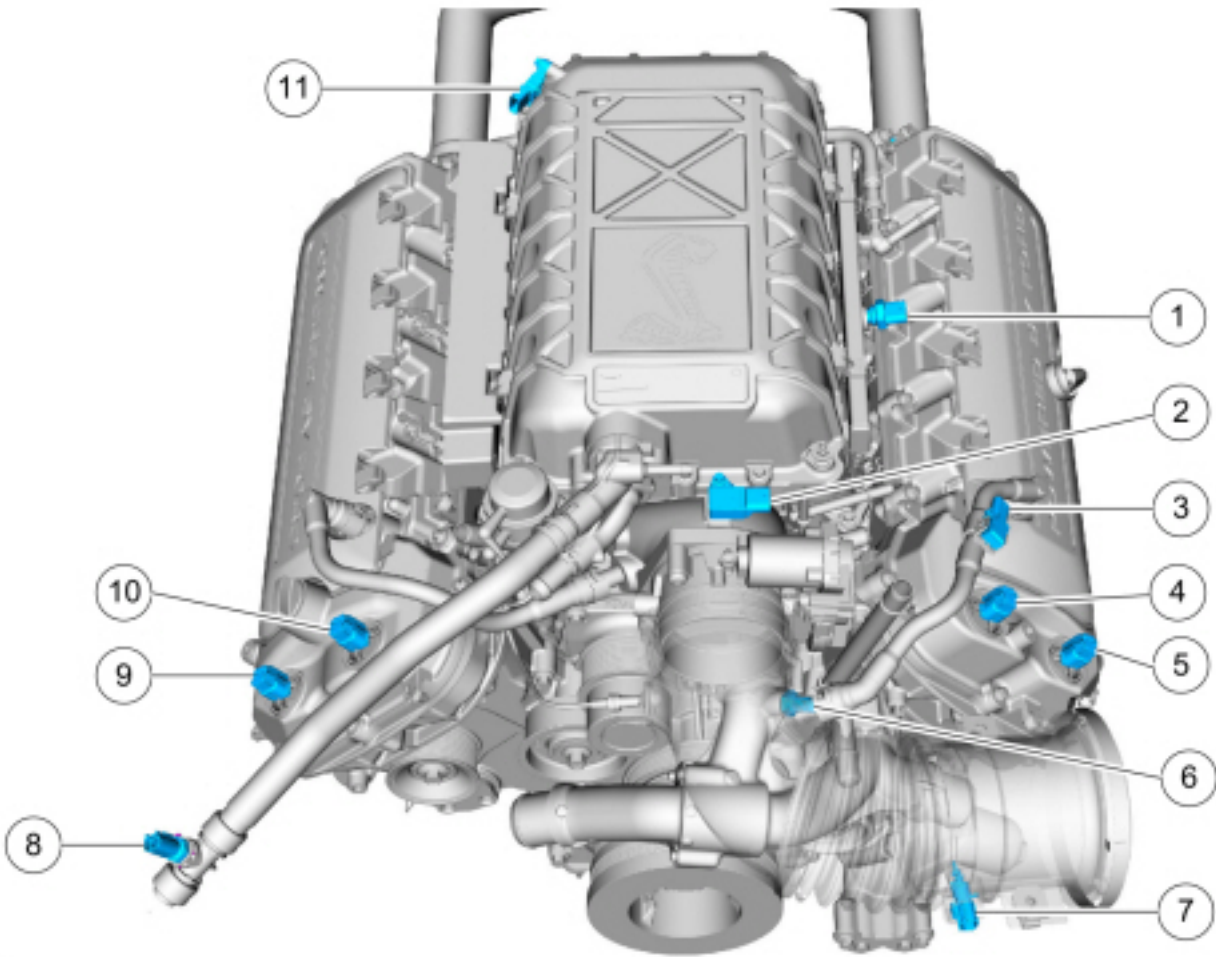

E308729

Electronic Engine Controls- Front Top

Item	Description
1	FRP and temperature sensor
2	MAPT sensor

3	Crankcase pressure sensor
4	LH intake VCT oil control solenoid
5	LH exhaust VCT oil control solenoid
6	ECT sensor
7	IAT sensor
8	Charge air cooler coolant temperature (CACCT) sensor
9	RH exhaust VCT oil control solenoid
10	RH intake VCT oil control solenoid
11	Turbocharger boost pressure sensor

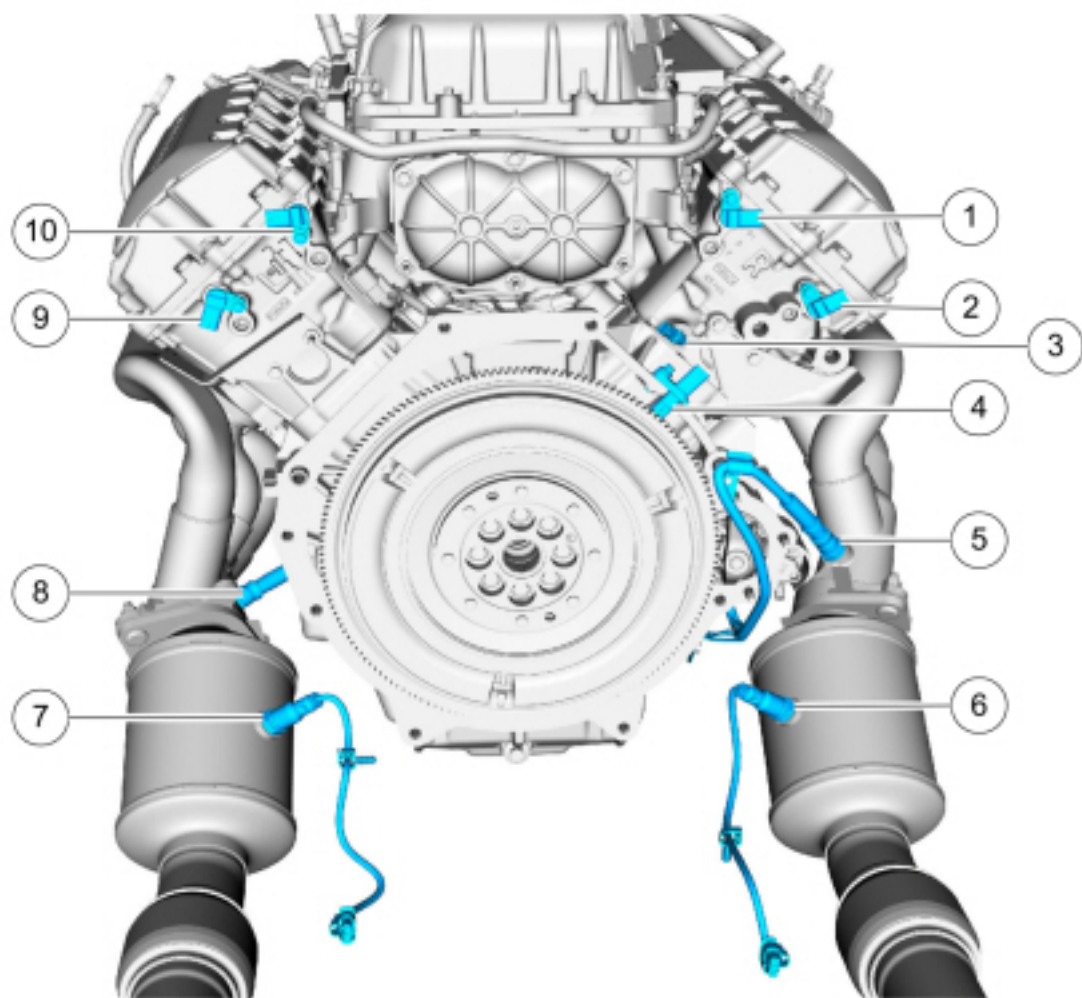

Electronic Engine Controls - Rear

Item	Description
1	RH intake CMP sensor
2	RH exhaust CMP sensor
3	CHT 2 (CHT2) sensor

4	CKP sensor
5	HO2S
6	Catalyst monitor sensor
7	Catalyst monitor sensor
8	HO2S
9	LH exhaust CMP sensor
10	LH intake CMP sensor

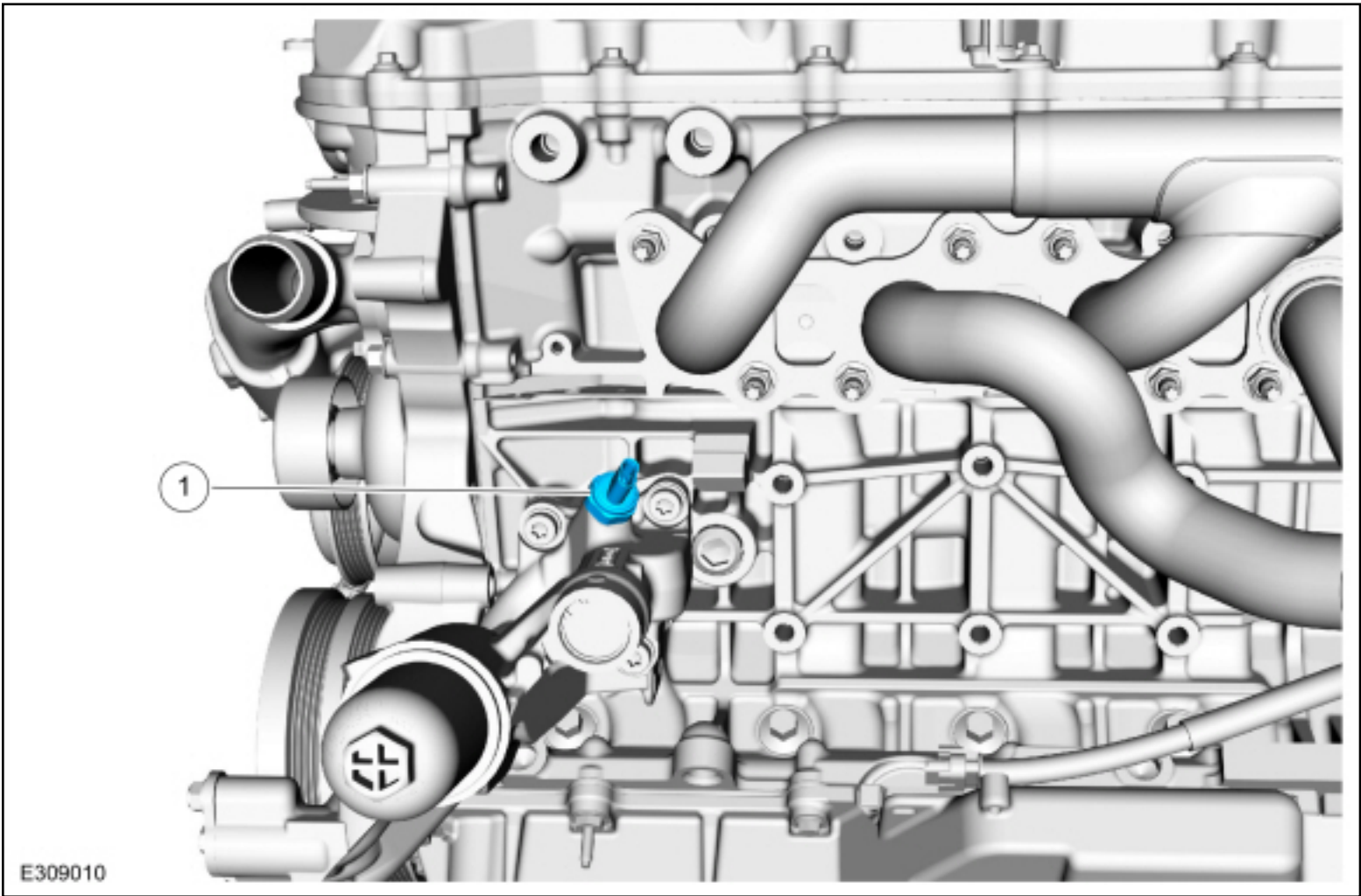

Electronic Engine Controls - Left side

Item	Description
1	EOP sensor

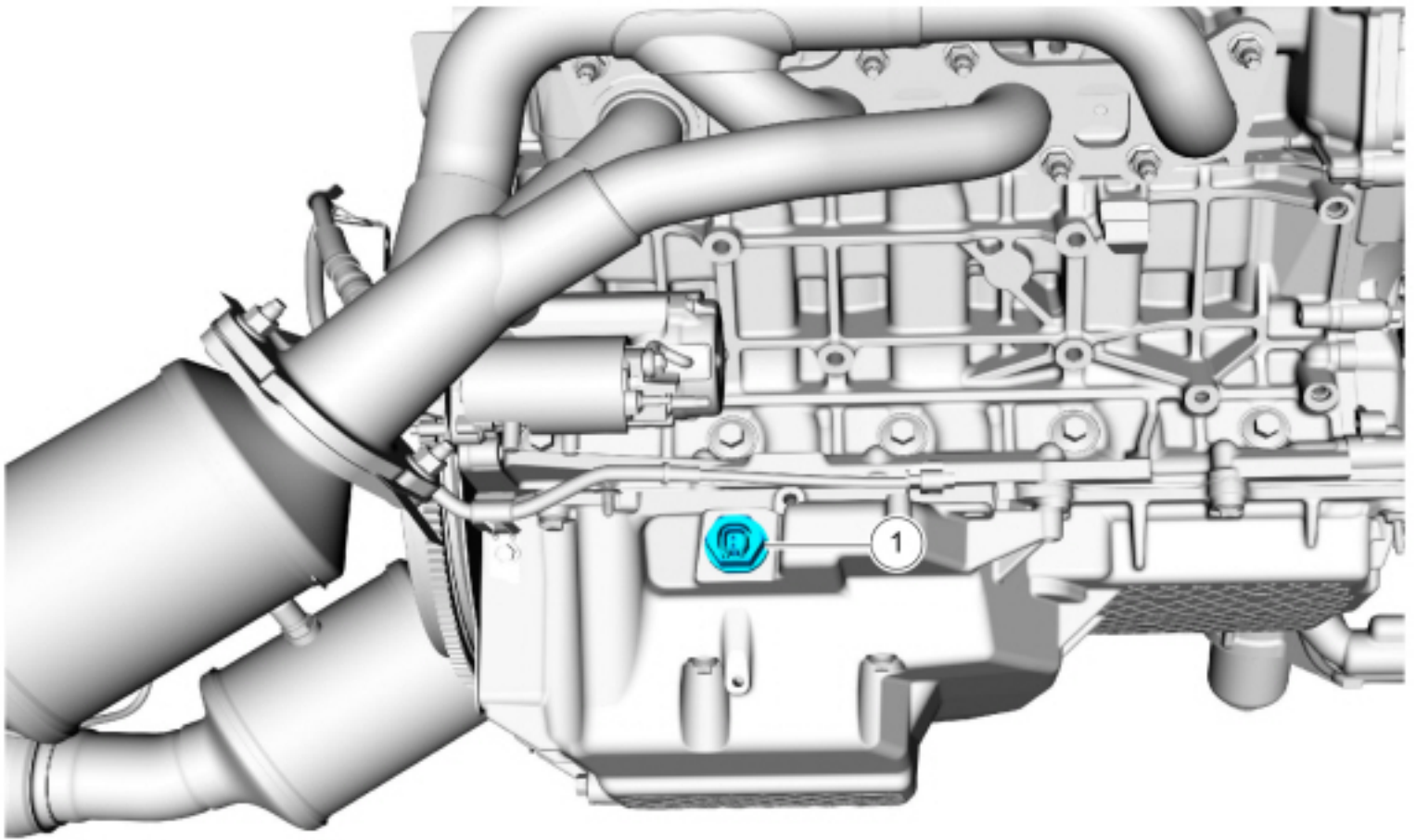

E309020

Electronic Engine Controls - Right side

Item	Description
1	Engine oil level sensor