

Critical Wear Areas & Vacuum Test Locations

NOTE: OE valves are shown in rest position and should be tested in rest position unless otherwise indicated. Test locations are pointed to with an arrow. Springs are not shown for visual clarity. Low vacuum reading indicates wear and Sonnax parts are noted for replacement.

Lower Valve Body • 10L80 (Gen. 1) Shown



For specific vacuum test information, refer to individual part instructions included in kits and available at www.sonnax.com.

Click on Sonnax part numbers to see more information.

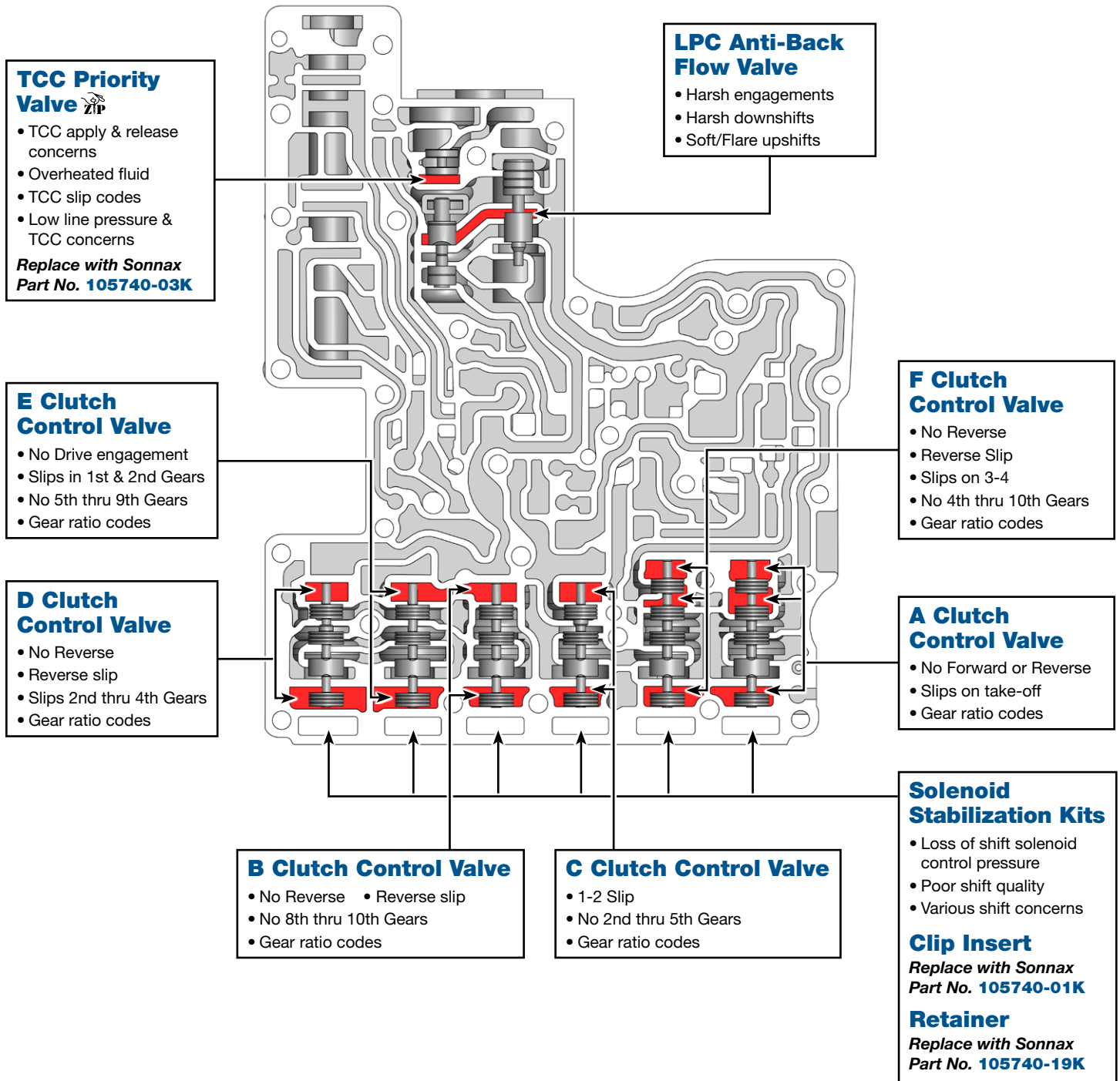

Critical Wear Areas & Vacuum Test Locations

NOTE: OE valves are shown in rest position and should be tested in rest position unless otherwise indicated. Test locations are pointed to with an arrow. Springs are not shown for visual clarity. Low vacuum reading indicates wear and Sonnax parts are noted for replacement.

Upper Valve Body • 10L80 (Gen. 1) Shown



For specific vacuum test information, refer to individual part instructions included in kits and available at www.sonnax.com.

Click on Sonnax part numbers to see more information.

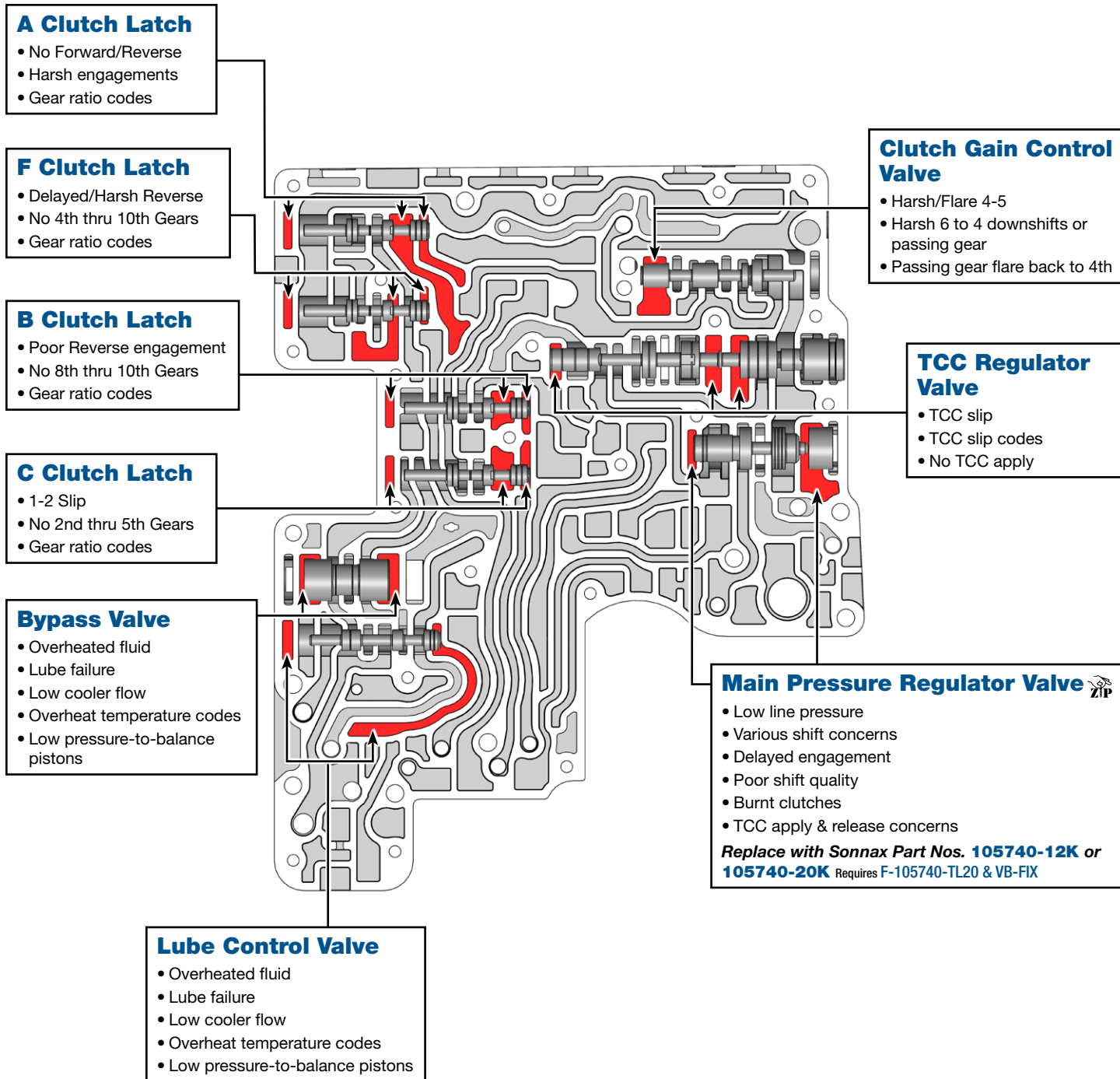

OE Exploded View

Lower Valve Body • 10L80 (Gen. 1) Shown

NOTE: Depending upon vehicle application, the OE springs shown may not be present.

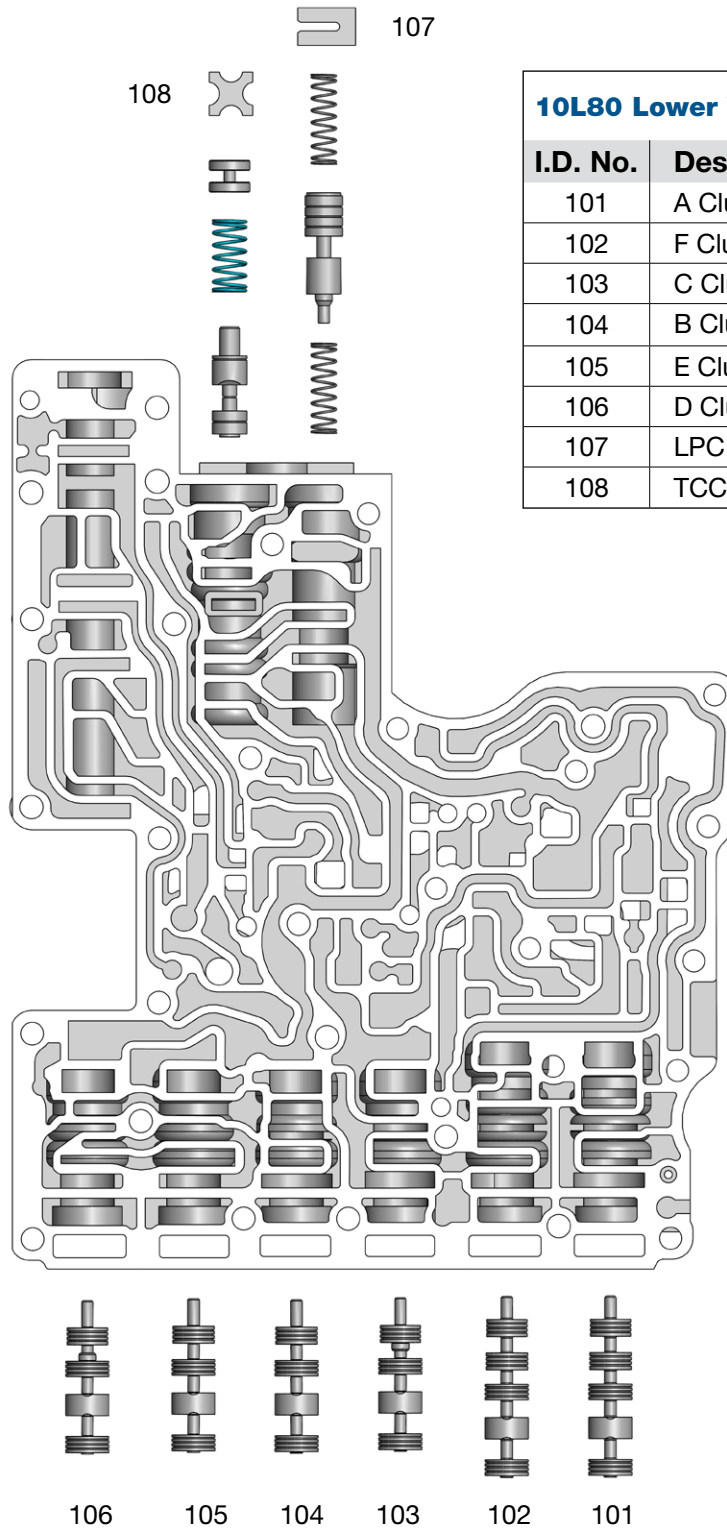

10L80 Lower Valve Body Descriptions	
I.D. No.	Description
101	A Clutch Control Valve
102	F Clutch Control Valve
103	C Clutch Control Valve
104	B Clutch Control Valve
105	E Clutch Control Valve
106	D Clutch Control Valve
107	LPC Anti-Back Flow Valve
108	TCC Priority Valve

OE Exploded View

Upper Valve Body • 10L80 (Gen. 1) Shown

NOTE: Depending upon vehicle application, the OE springs shown may not be present.

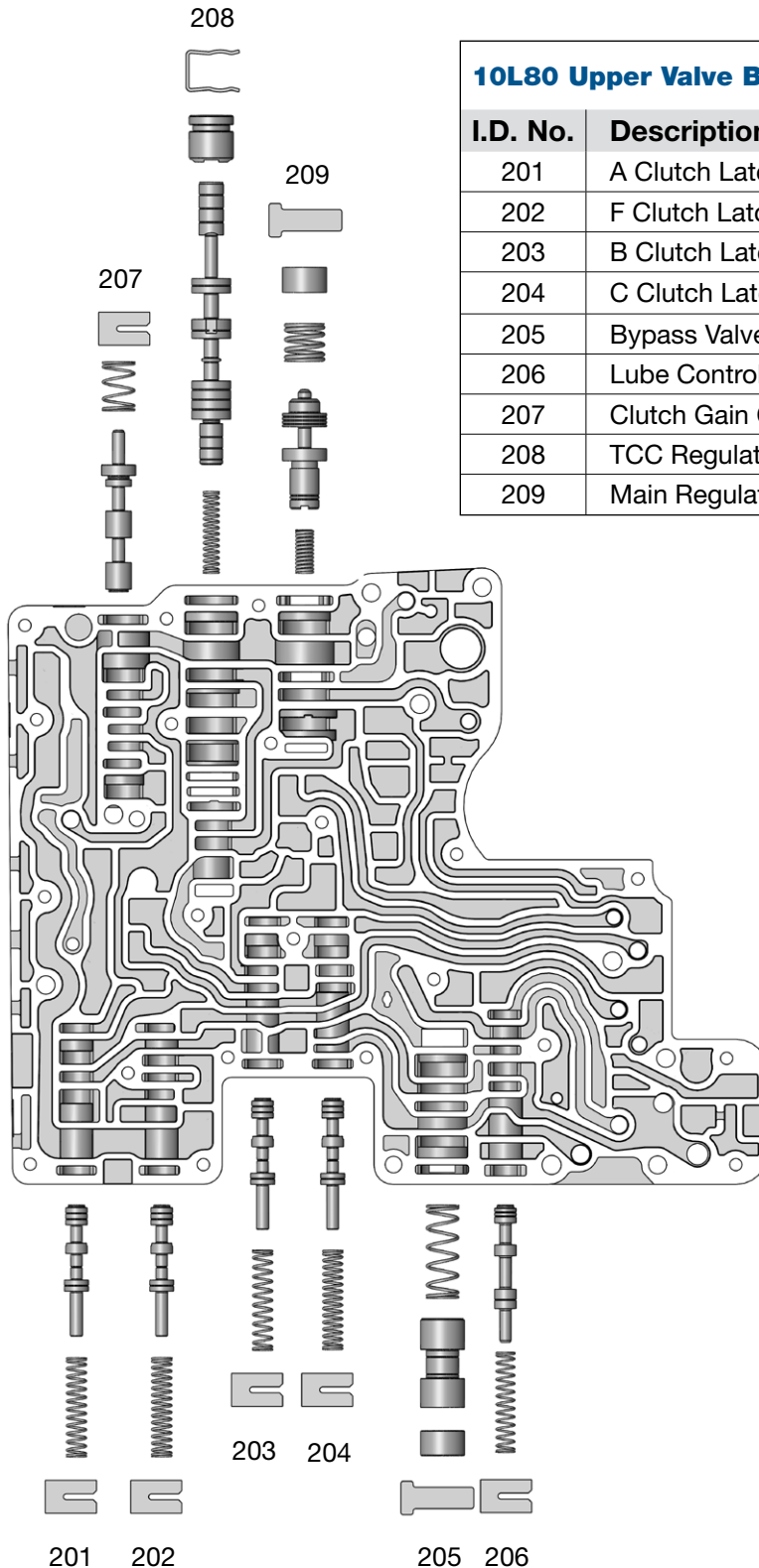

10L80 Upper Valve Body Descriptions	
I.D. No.	Description
201	A Clutch Latch Valve
202	F Clutch Latch Valve
203	B Clutch Latch Valve
204	C Clutch Latch Valve
205	Bypass Valve
206	Lube Control Valve
207	Clutch Gain Control Valve
208	TCC Regulator Valve
209	Main Regulator Valve